

DISCLAIMER: The use of this standard is governed by the "Texas Engineering Practice Act". No warranty of any kind is made by TxDOT for any purpose whatsoever. TxDOT assumes no responsibility for the conversion of this standard to other formats or for incorrect results or damages resulting from its use.

DATE: FILE:

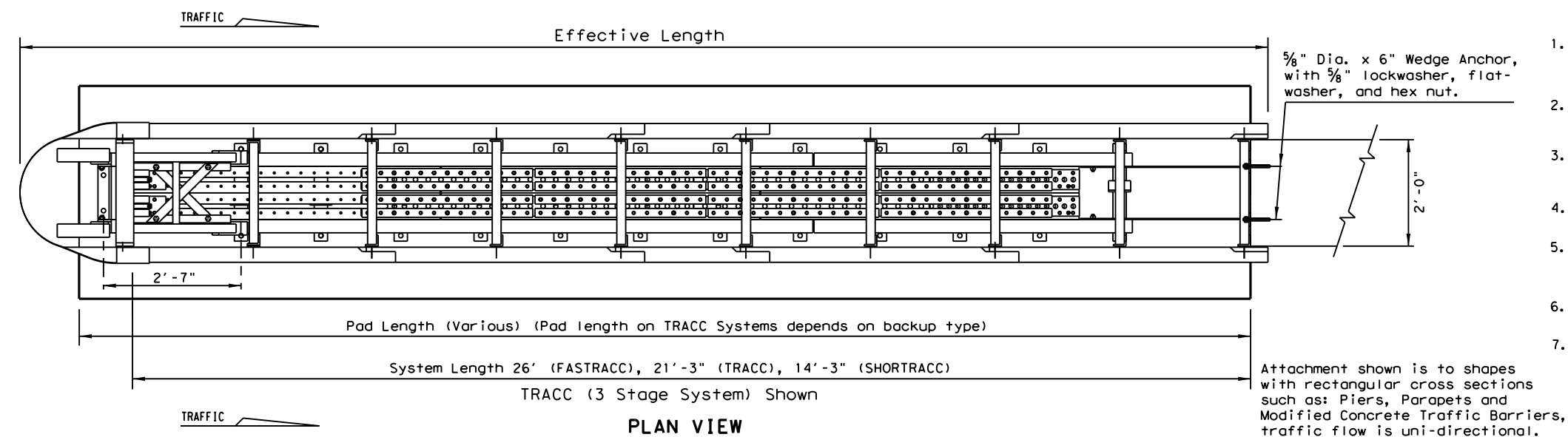

- GENERAL NOTES**
1. For specific information regarding installation and technical guidance of the system, contact: Trinity Highway at 1(888)323-6374, 2525 N. Stemmons Freeway - Dallas, TX 75207
 2. For bi-directional traffic, appropriate transition panels will be required.
 3. Details of components for the TRACC and backups and reinforcing details will be shown on the manufacturer's shop drawings furnished to the Engineer.
 4. Concrete shall be class "S" with a minimum compressive strength of 4,000 p.s.i.
 5. If the cross-slope varies more than 2% over the length of the system, the concrete pad will require leveling. Maximum permissible cross-slope is 8%.
 6. The installation area should be free from curbs, elevated objects, or depressions.
 7. The TRACC system should be approximately parallel with the barrier or $\frac{1}{2}$ of merging barriers.

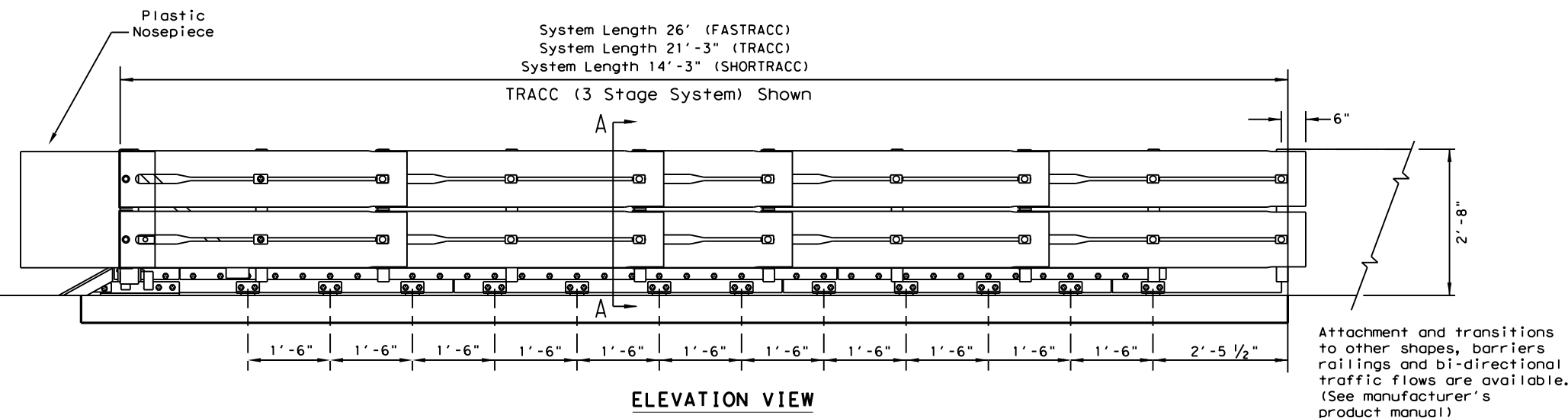

				BILL OF MATERIAL
PART #	QTY	QTY	QTY	DESCRIPTION
25936A	1			FASTRACC Unit Assembly
25980A		1		TRACC Unit Assembly
25997A			1	SHORTTRACC Unit Assembly
3310G	4	4	4	5/8" Lockwasher
4451G	4	4	4	5/8" Dia x 6" Wedge Exp. Anchor
6531B	1	1	1	Plastic Nosepiece
6668B	4	4	4	Reflective Sheeting
* ANCHOR HARDWARE (CONCRETE BASE)				
5204G	32	26	18	5/8" Dia x 7 1/2" All Thd. Rod
3310G	32	26	18	5/8" Lockwasher
3361G	32	26	18	5/8" Hex Nut
3300G	32	26	18	5/8" Flat Washer
5206B	3	3	2	TRACC Adhesive HIT HY150 Kit
* ANCHOR HARDWARE (ASPHALT BASE)				
6380G	32	26	18	5/8" Dia x 18" All Thd. Rod
3310G	32	26	18	5/8" Lockwasher
3361G	32	26	18	5/8" Hex Nut
3300G	32	26	18	5/8" Flat Washer
5206B	7	5	4	TRACC Adhesive HIT HY150 Kit

* See manufacturer's product manual

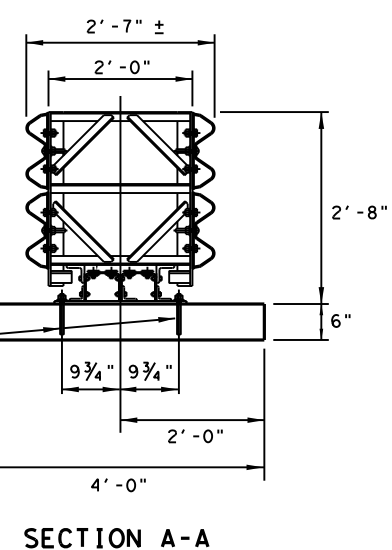

BACKUP SUPPORT OPTIONS	
Square Concrete Backup	
Concrete Barrier (CTB) Backup	
Single Slope Concrete Barrier (SSCB)	
Guardrail Backup (Base-Plated Post)	
Guardrail Backup (Driven Post)	
TRANSITION OPTIONS	
Vertical Wall	
Modified (CTB) to Vertical Wall	
Concrete Barrier (CTB)	
Guardrail (W-Beam)	
Guardrail (Thrie-Beam)	

For bi-directional transition panel details (See manufacturer's product manual)
 Backup and Transition types are shown elsewhere on the plans, (i.e. Attenuator location details or in the general notes).

TYPE (NARROW)	TEST LEVEL	SYSTEM LENGTH	EFFECTIVE LENGTH	PAD LENGTHS
FASTRACC (4 Stage System)	70	26'	27'- 9"	26'- 8"
TRACC (3 Stage System)	TL-3	21'- 3"	23'- 0"	22'- 0" 23'- 0" 24'- 0"
SHORTTRACC (2 Stage System)	TL-2	14'- 3"	16'- 0"	15'- 0" 16'- 0" 17'- 0"

The Stage System refers to number of replaceable sled sections that could be replaced independently. Concrete pad length on TRACC & SHORTTRACC depends on backup type.

FOUNDATION OPTIONS
6" Reinforced Concrete
8" Unreinforced Concrete
3" Min. Asphalt over 3" Min. Concrete
6" Asphalt over 6" Compact Subbase
8" Minimum Asphalt

For steel placement in concrete foundations (See manufacturer's product manual)

REUSABLE

TRINITY HIGHWAY
CRASH CUSHION
(NARROW)
TRACC (N) - 16

FILE: traccn16.dgn	DN: TxDOT	CK: KM	DW: VP	CK: VP
© TxDOT: February 2006	CONT	SECT	JOB	HIGHWAY
REVISIONS				
REVISED 06, 2013 (VP)				
REVISED 03, 2016 (VP)				
DIST	COUNTY	SHEET NO.		